

USB2.0 InGaAs NIR CAMERA

ARTCAM-TNIR series

INSTRUCTION BOOKLET

0.33 M pixels ARTCAM-031TNIR series

0.08 M pixels ARTCAM-008TNIR series

0.016 M pixels ARTCAM-0016TNIR series

ARTRAY

ARTRAY CO., LTD.

Contents

1. Attention	3
2. Introduction.....	6
3. Main Features.....	6
4. The Product.....	7
5. Connect the Camera.....	7
6. Specifications.....	8
7. Spectral sensitivity characteristics	9
8. External Dimensions	11
9. Optional function.....	14
10. Recommended PC.....	18

1. Attention

■ About this manual

1. Before using the camera, please read this manual thoroughly.
2. Please keep this manual reachable and always refer to the contents when needed.
3. Please contact us if the manual is lost or damaged. We will provide a replacement.
4. We cannot guarantee the safety of improper uses of the camera.
5. For your safety, please follow the directions of this manual.
6. All contents are subject to change.
7. Images in this manual may have been simplified to be easier comprehended.
8. Please contact us if you find any unclear points or mistakes in this manual.
9. Quoting, copying or altering some or all parts of the manual without our permission is prohibited.
10. We are not responsible for any lost or damages on your profits due to the use of our products.
11. Please understand that our oversea branches do not provide maintenance or repair services.

■ About the Icons

To keep the safety of the user, other people and their properties, please pay attention to the following icons.



Warning

If the user fails to follow the instruction, physical injury on human or damages on hardware may occur.



Caution

If the user fails to follow the instruction, serious injury or death may occur.

■For Safe Use



Warning

●In following circumstances, please stop using the product and turn off the power immediately to prevent the risks of fires and electric shocks. If the product is defective, please contact us for repair or exchange. For your safety, please do not disassemble, modify or repair the camera on your own.

Please stop using the product and turn off the power immediately when :

- The product becomes smoky or gets extremely hot on the surface, or makes unusual smells or sounds.
- Foreign material or water gets into the product.
- The product falls and becomes damaged.

●Do not place the product on unstable surfaces. The product may be fallen and people may get hurt.



Caution

●Do not expose the product to steam or fumes to avoid electric shocks and fires.

●Do not leave the product in high temperature places such as inside of vehicles or under direct sunlight. High temperature may cause damages to the camera, or even cause fires.

●Do not cover the product with cloth or other materials. The product may get extremely hot and the heat may cause deformations on the parts or even cause fires.

●Please avoid dropping or shocking the product as the product may be damaged.

●Do not touch the cable with a wet hand. Such action may cause electric shocks.

●Please avoid continuously contacting the surface of the camera to your skin when the camera is being used. The surface temperature of the camera may cause burns.

■Other Notices

●Please do not use the camera under strong lights such as sun light for a long period. Also please do not expose the camera under strong lights even when the product is not being used because the sensor might be damaged.

Maintenance

● Wipe the dirt on surface with soft cloth or tissue paper. Do not use alcohol, thinner or benzene to avoid damaging the surface paints.

Electro Magnetic Interference

●The camera may interference with electronic devices such as TV and radio. Please do not place the camera next to such equipment.

■Export Control

This product is a List Control item subject to the Foreign Exchange and Foreign Trade Act and its relevant legislations No.1 10 (2) and (4). To export this product from Japan, obtaining export licenses from the Ministry of Economy, Trade and Industry is required. It is also necessary for our company to manage the information of users and the purposes of use. If the end users or purposes of use change after the purchase and thus cause the need to apply export licenses from Ministry of Economy, Trade and Industry, please contact the sales representative in advance.

■Guarantee

To save the environment, we do not issue warranty in printed format. Instead, all records of the warranty periods, delivery dates and the customer information are well kept in our system.

For more details, please refer to the sites below:

Hardware Warranty: http://www.artray.us/download/artray_warranty.pdf

■Dispose

To dispose this product, please return the camera to us. If you decide to dispose the camera without returning it us, please follow related regulations and have the camera disposed as an industrial waste. Please always keep records of the dispose, and make sure the disposed camera cannot be accessed or used by any 3rd party.

■Limited Responsibility

We do not guarantee the functions of this product or the descriptions on this manual to be completely adapted to the users' end applications or marketing purposes. We are also not held responsible for any direct or indirect damages caused by our products under any circumstances.

Please do not use this product on applications that require high reliability. This product is not manufactured to be used as medical, nuclear, aerospace, transportation equipment or equipment that is highly related to human safety. We are not held responsible for any damages on the users' property, equipment or personal safety caused by this product.

2. Introduction

ARTCAM-TNIR series include 3 kinds of NIR camera which adopts a 640 x 512 / 320 x 256 /128 x 128 InGaAs (Indium gallium arsenide) sensor. The cameras have a high sensitive spectral response from 900 nm to 1700 nm.

ARTCAM-TNIR series adopts USB2.0 interface, so image data can be delivered to PC directly without a capture board. Also, this camera is equipped with an on board memory which avoid data missing during transfer.

3. Main Features

- NIR Detection with High Sensitivity

The InGaAs sensor can detect radiation invisible to human eyes and CCD/CMOS cameras in the wavelength range between 900 nm to 1700 nm band.

- High Resolution, High Frame Rate

ARTCAM-031TNIR uses a higher resolution sensor of 640 x 512 pixel and delivers image at 27.4 frame/second

ARTCAM-008TNIR uses 320 x 256 pixel sensor and delivers high-speed imaging at 90 frame/second.

ARTCAM-008TNIR uses 128 x 128 pixel sensor and delivers high-speed imaging at 258 frame/second.

- USB2.0 Interface

This camera adopts USB2.0 interface, so the data can be delivered to PC directly. No capture board is needed.

- TEC(Thermoelectric Cooling) Function

ARTCAM-031TNIR equipped with Thermoelectric Cooling function to improve the data reliability.

- InGaAs Camera Viewer Software

The camera comes with ART-VIEWER the bonded viewer software (Windows XP/Vista/7/8). With this software, users can easily preview images, save images and change camera settings.

- Software Development Kit

For customer who prefers to create their own image processing software or use our camera with other applications, we provide SDK upon requests.

4. The Product

- 1) Camera
- 2) USB Cable Type A-B connector cable, 3m approx.
- 3) AC adapter (DC12V)
- 4) Introduction Booklet
- 5) Viewer software/Device Driver CD
- 6) Software Development Kit, ARTCCM-SDK

<Options>

- 1) NIR Lenses (C Mount Lens)
- 2) 5m extension cable with USB2.0 repeater

5. Connect the Camera

5-1 How to connect a camera

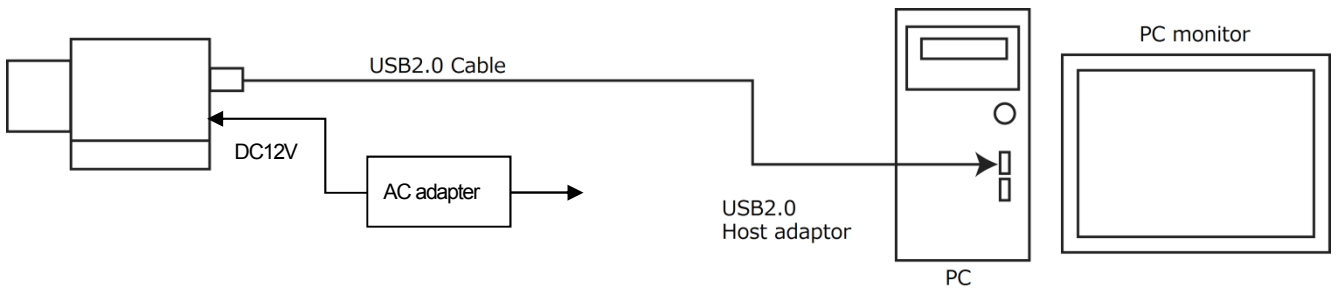

5-2 Shutter Speed

Shutter speed can be changed on the standard viewer software ART-Viewer.

The shutter speed is set directly on the sensor register, so please refer to the following formulas for the real exposure time.

Model	Method
ARTCAM-031TNIR	Range : 0~65500(Exposure Time : 1/833333~4.408sec) Exposure Time=(640+33) x Shutter Value x 0.1 [μsec] *1. When setting is 0, 12*0.1 [μsec] *2. To drive at 640×512 pixels, 10.00MHz
ARTCAM-008TNIR	Range : 1~32767(Exposure Time : 1/25706~1.27sec) Exposure Time=(320+69) x Shutter Value x 0.1 [μsec] * To drive at 320×256 pixels, 10.00MHz
ARTCAM-0016TNIR	Range : 5~65535(Exposure Time : 1/1000000~1/76.29sec) Exposure Time=Shutter Value x 0.2 [μsec] *To drive at 128×128 pixels, 20.00MHz

6. Specifications

	ARTCAM-031TNIR	ARTCAM-008TNIR	ARTCAM-0016TNIR
Sensor Type	InGaAs Image Sensor		
Number of effective pixels	640(H)x512(V)	320(H)x256(V)	128(H)x128(V)
Resolution	640(H)x512(V)	320(H)x256(V)	128(H)x128(V)
Active Imager Size	16.0(H)x12.8(V)mm 1.28"	9.6(H)x7.68(V)mm	2.56(H)x2.56(V)mm
Scan Mode	Progressive Scan		
Pixel Size	25(H)x25(V) μ m	30(H)x30(V) μ m	20(H)x20(V) μ m
Detected Wavelength	900~1700nm		950~1700nm
Operability	>99%		
Shutter Type	Global Shutter		
Frame Rate	27.4fps	90fps	258fps
Shutter Speed	1/833333~4.408sec	1/25706 ~1.27 sec	1/1000000~13.107 sec
Detectivity	$\geq 5 \times 10^{12}$ Jones		—
Gain	High Gain : 23.6 μ V/e- Low Gain : 1.26 μ V/e-	High Gain : 13.3 μ V/e- Low Gain : 0.7 μ V/e-	—
Full Well Capacity	High Gain : 118Ke- Low Gain : 1.9Me-	High Gain : 170Ke- Low Gain : 3.5Me-	—
A/D Resolution	12bit	14bit	
Interface	USB2.0 Bulk Transfer		
Synchronization System	Internal Synchronization		
Lens Mount	C Mount		
Power	DC12V		
Power Consumption	Under Approx.20W		
Ambient Conditions	Operating Temperature/Humidity : 0~35°C/10~80%(Non condensing)		
	Storage Temperature/Humidity : 0~60°C/10~95%(Non condensing)		
External Dimensions	71.5(W)x61.5(H)x125(D)mm *Lens, tripod and cables not included	71.5(W)x61.5(H)x51.8(D)mm *Lens, tripod and cables not included	71.5(W)x61.5(H)x61.5(D)mm *Lens, tripod and cables not included
Weight	Approx. 400g *Lens, tripod and cables not included	Approx. 250g *Lens, tripod and cables not included	Approx. 260g *Lens, tripod and cables not included

Depending on lens you use, our product might not reach the best condition and problems, such as the low resolution and lightness, might occur.

Please consult our sales representative for the recommended lenses.

7. Spectral sensitivity characteristics

7-1 ARTCAM-031TNIR

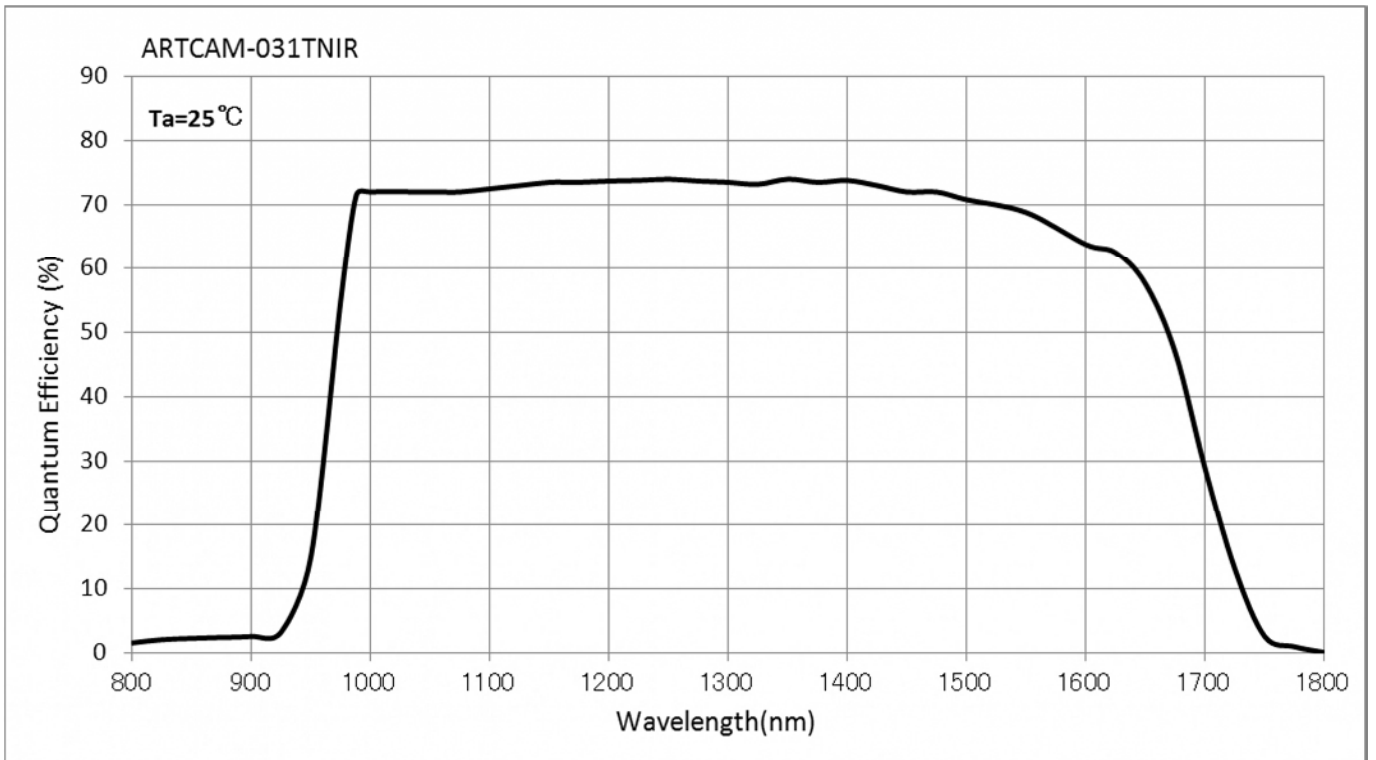

7-2 ARTCAM-008TNIR

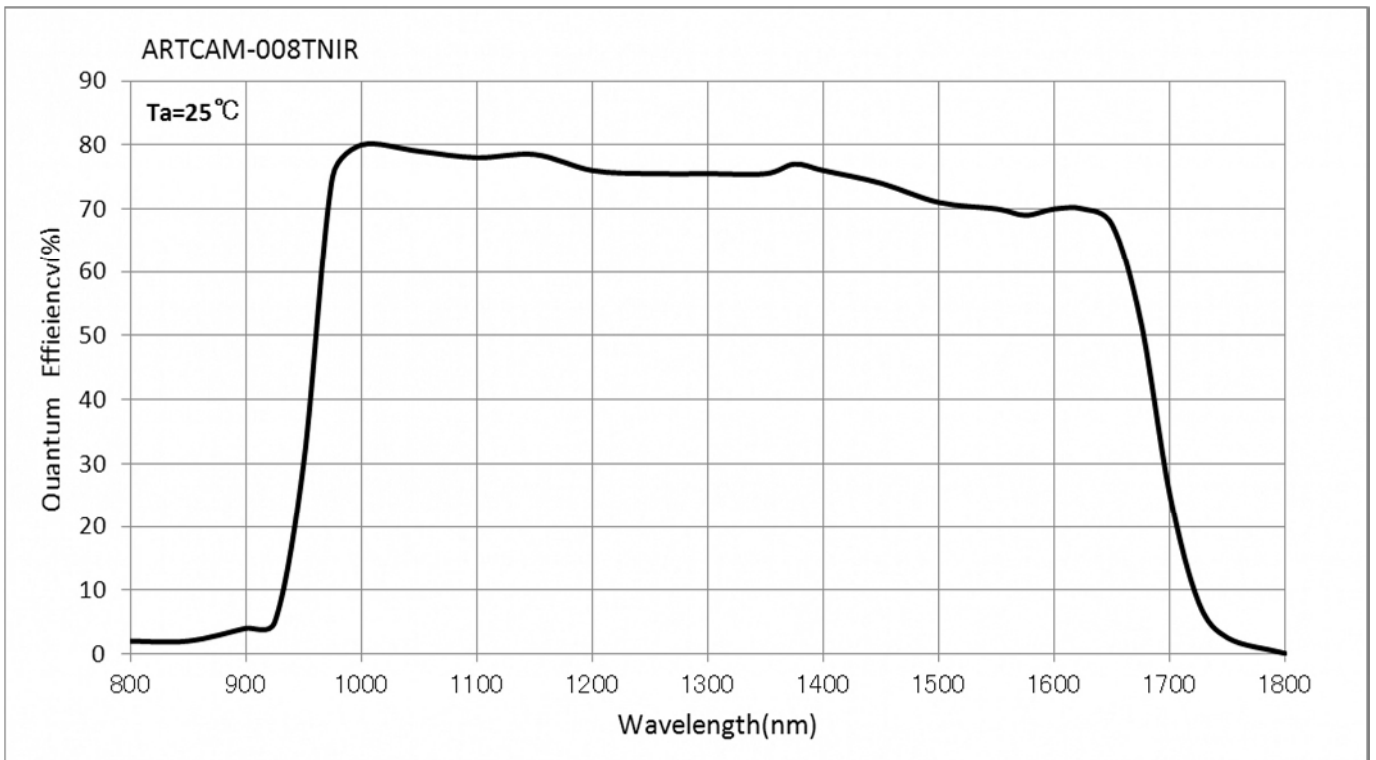

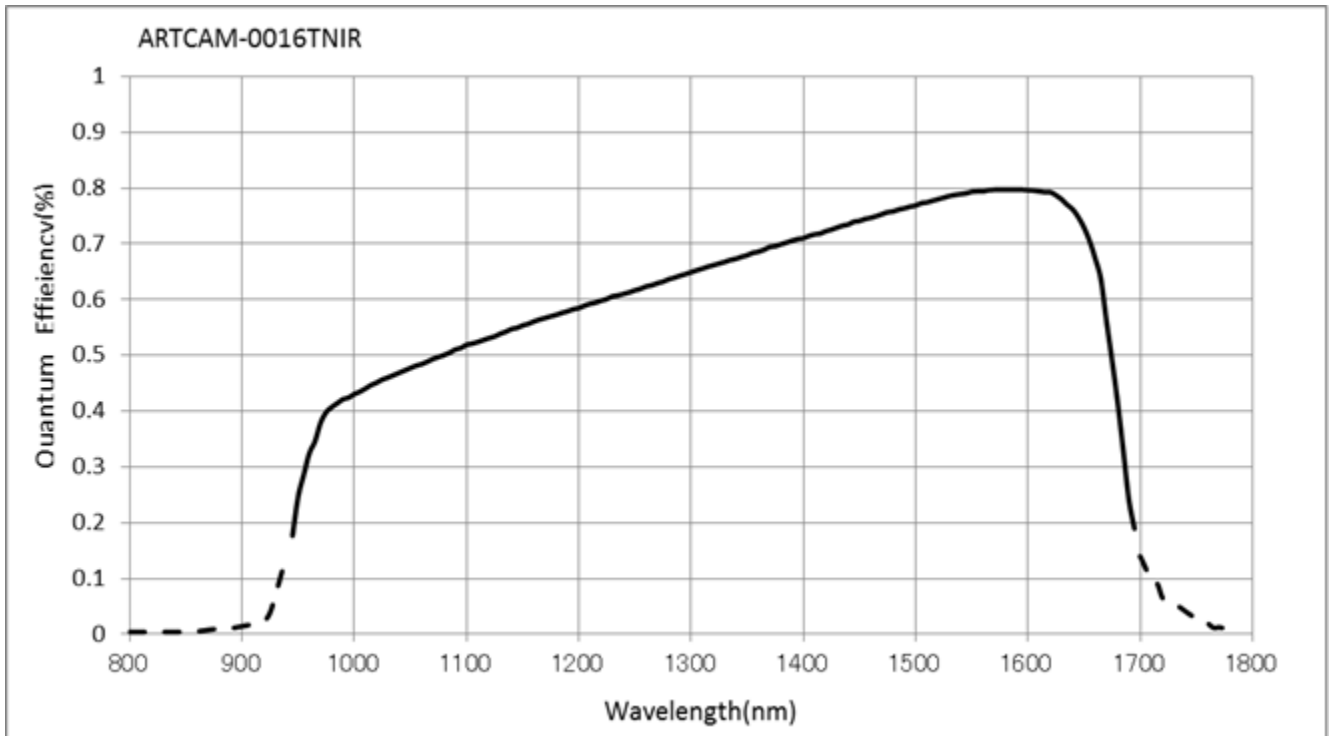

8. External Dimensions

8-1 ARTCAM-031TNIR

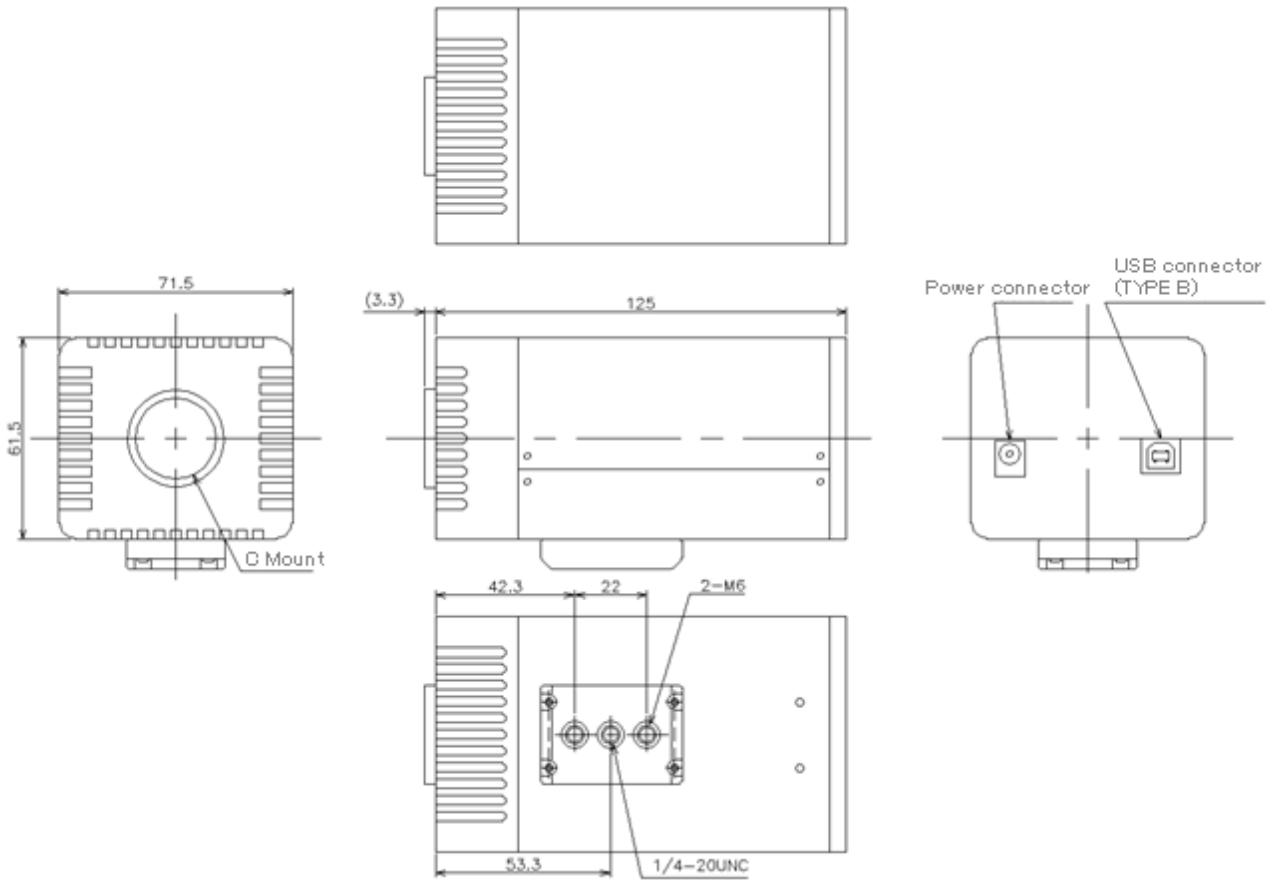

8-2 ARTCAM-008TNIR

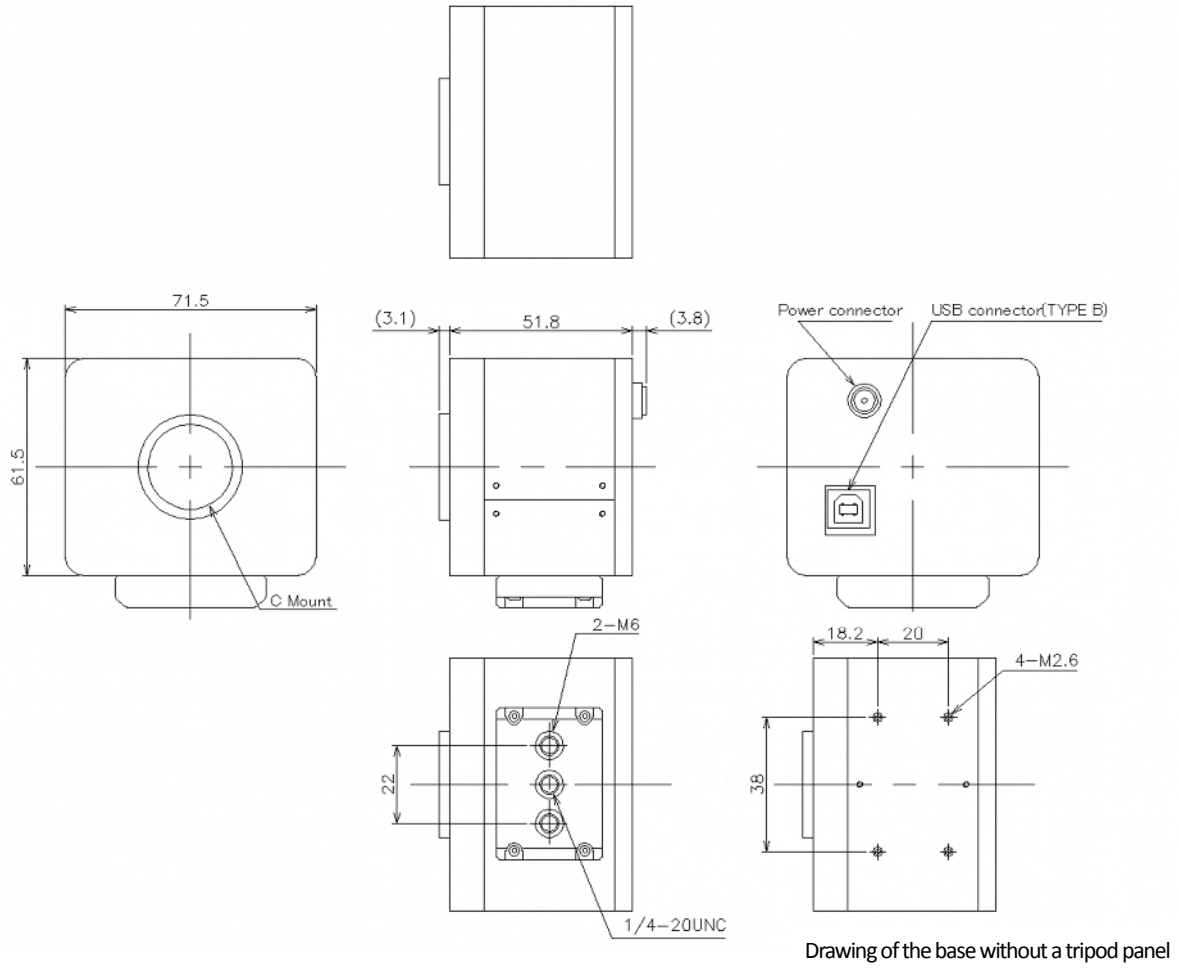

*The design has changed into the small case model of this outline drawing for orders after Jan, 2013.

8-3 ARTCAM-0016TNIR

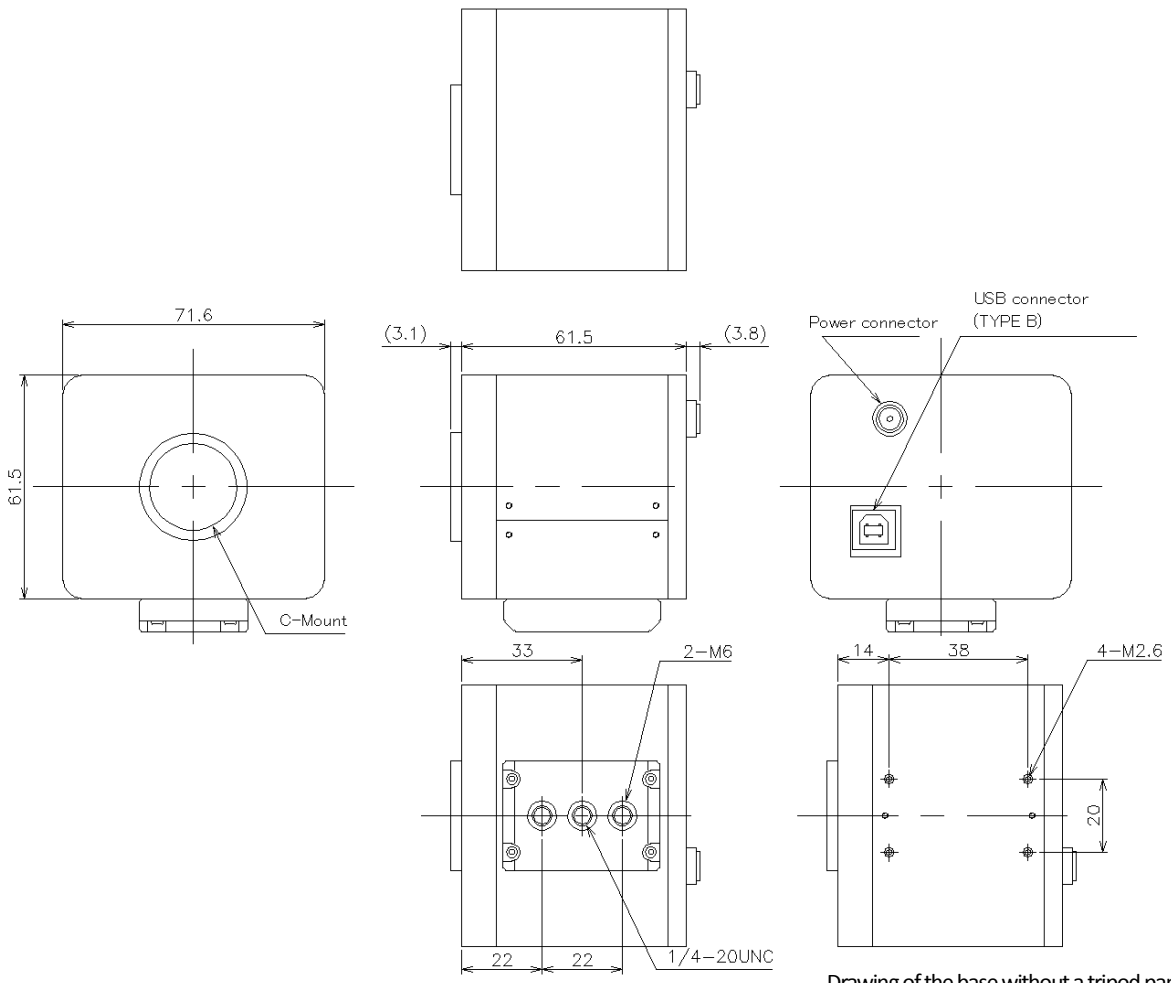

Drawing of the base without a tripod panel

9. Optional Functions

9-1 External trigger function

ARTCAM-TNIR series are designed to work with external trigger.

(Following input circuit diagram applies to 031TNIR, 008TNIR, 0016TNIR)

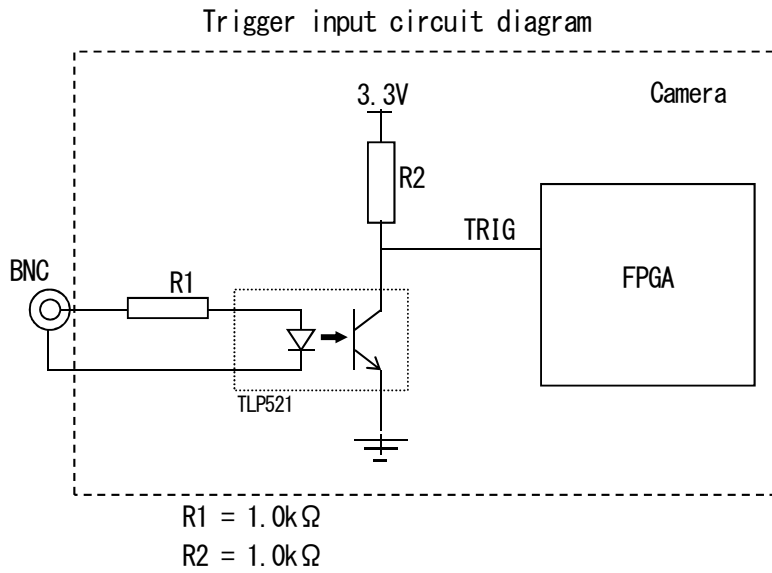

*Please advise us if you need this function when you place an order.

9-2 Trigger - Timing Diagram (ARTCAM-031TNIR series)

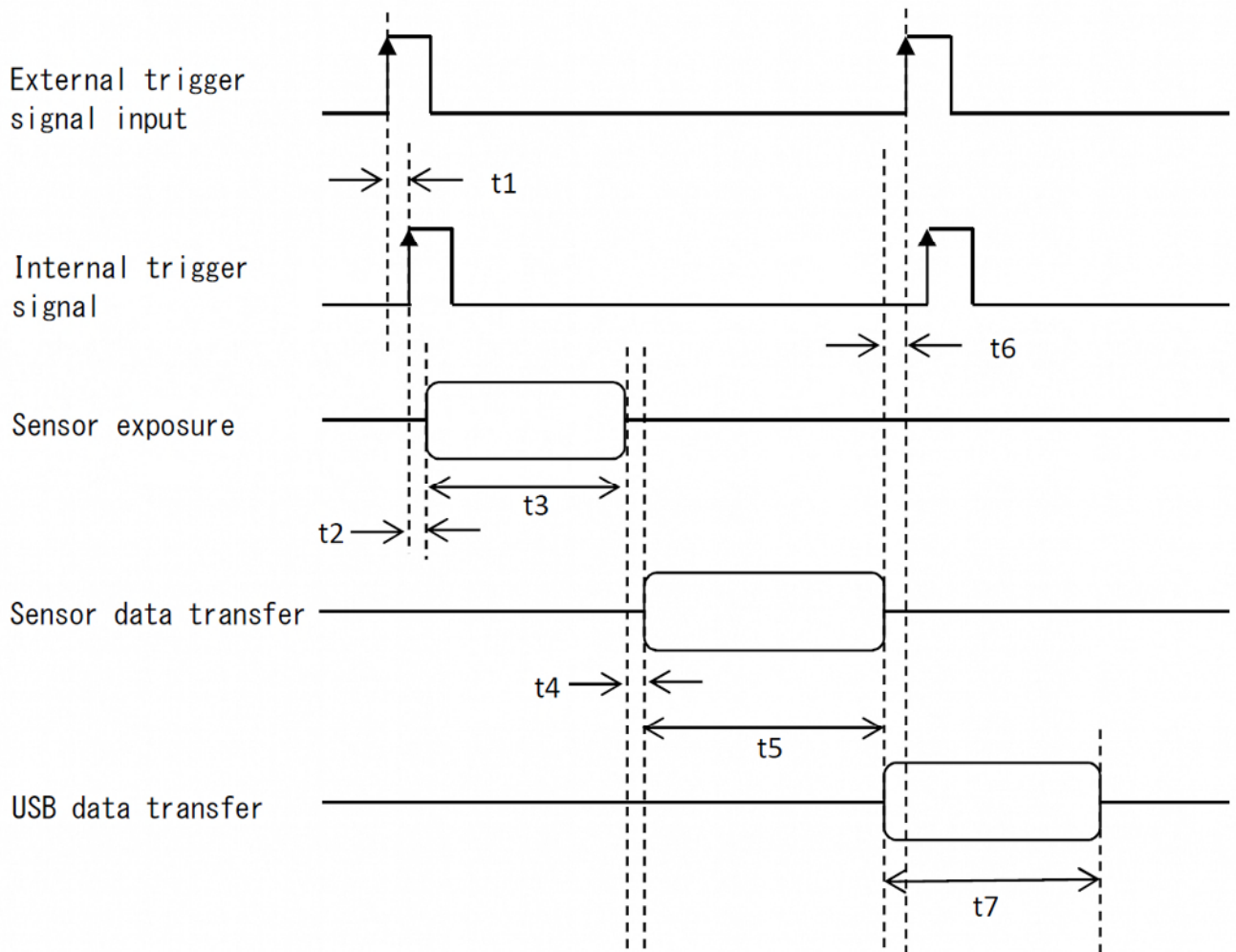

No.	ITEM	TIME
t1	From the rising edge of external trigger input Until rise of internal trigger signal (Delay due to photo coupler)	1 μ s or less
t2	From the rising edge of the internal trigger input Until the exposure starts	26PCLK (1PCLK = 1/10000000s = 0.1 μ s)
t3	Exposure time	Shutter speed setting value * 1H * 1H = (effective horizontal pixel number + 33) * 1PCLK
t4	Delay from completion of exposure to data transfer in the camera	4H
t5	Data transfer time (sensor to FPGA)	Number of effective vertical pixels * 1H
t6	From the completion of internal data transfer Time until the next trigger input is enabled	30H
t7	USB data transfer time	Approximately 16msec (depending on PC spec, USB transfer rate)

9-3 Trigger - Timing Diagram (ARTCAM-008TNIR series)

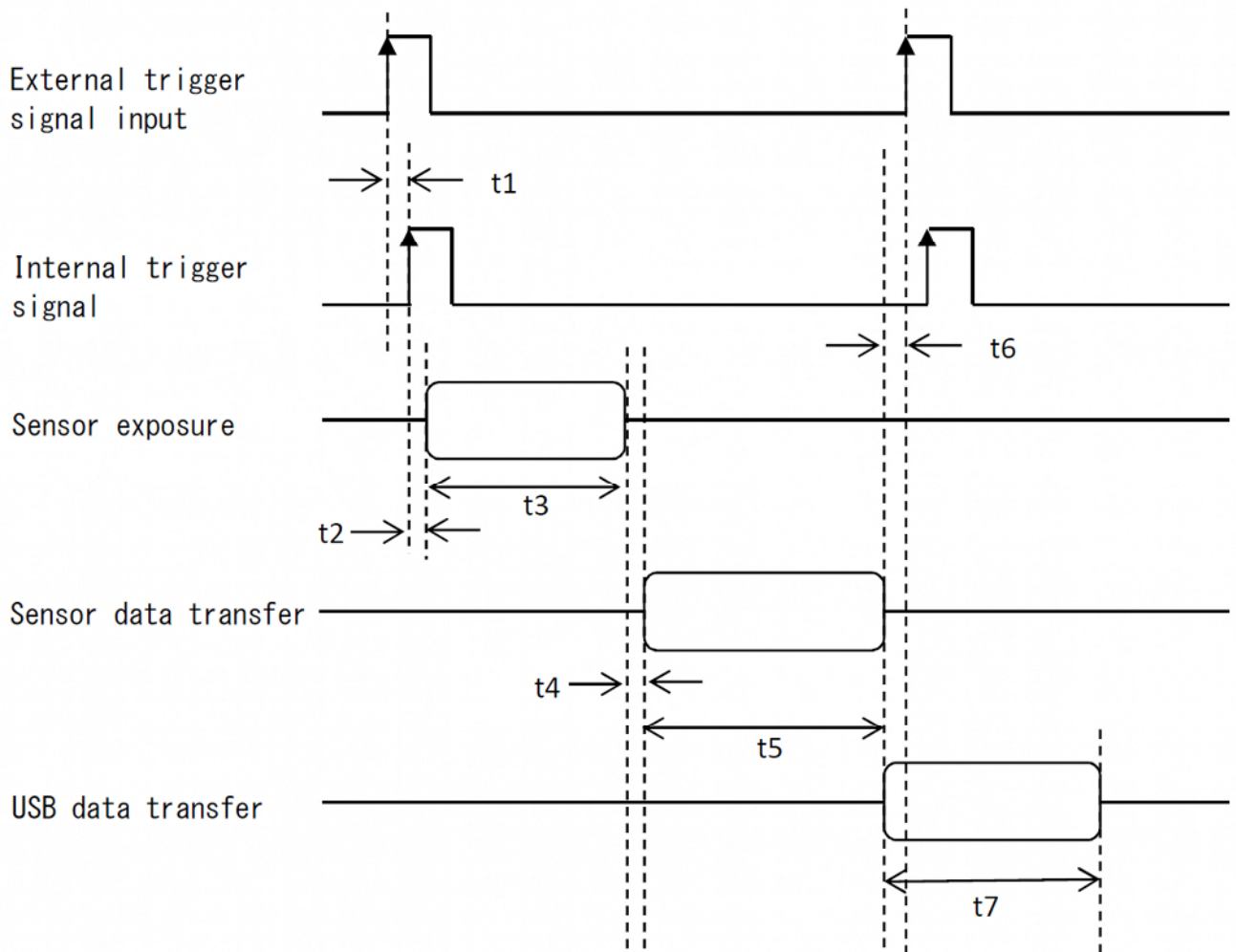

No.	ITEM	TIME
t1	From the rising edge of external trigger input Until rise of internal trigger signal (Delay due to photo coupler)	1 μ s or less
t2	From the rising edge of the internal trigger input Until the exposure starts	26PCLK (1PCLK = 1/10000000s = 0.1 μ s)
t3	Exposure time	Shutter speed setting value * 1H * 1H = (effective horizontal pixel number + 69) * 1PCLK
t4	Delay from completion of exposure to data transfer in the camera	4H
t5	Data transfer time (sensor to FPGA)	Number of effective vertical pixels * 1H
t6	From the completion of internal data transfer Time until the next trigger input is enabled	30H
t7	USB data transfer time	Approximately 4msec (depending on PC spec, USB transfer rate)

9-4 Trigger - Timing Diagram (ARTCAM-0016TNIR series)

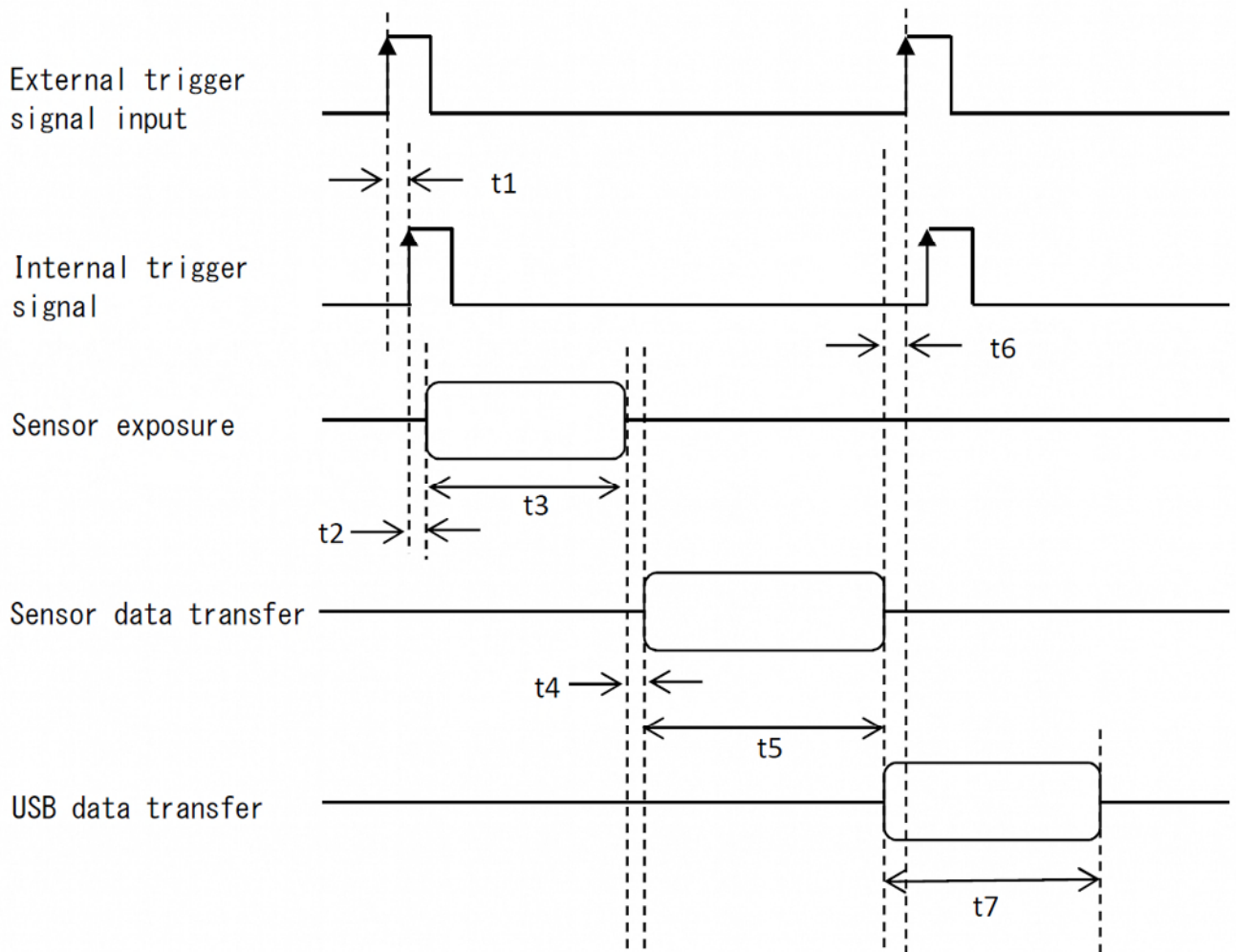

No.	ITEM	TIME
t1	From the rising edge of external trigger input Until rise of internal trigger signal (Delay due to photo coupler)	1 μ s or less
t2	From the rising edge of the internal trigger input Until the exposure starts	1PCLK (1PCLK = 1/5000000s = 0.2 μ s)
t3	Exposure time	Shutter speed setting value * 1PCLK
t4	Delay from completion of exposure to data transfer in the camera	4.55 μ s
t5	Data transfer time (sensor to FPGA)	3.84ms
t6	From the completion of internal data transfer Time until the next trigger input is enabled	25.6 μ s
t7	USB data transfer time	Approximately 4msec (depending on PC spec, USB transfer rate)

10. Recommended PC

10-1 Recommended System Requirements

- Intel chip set, Southbridge above ICH6
- CPU: Intel Core2duo 2.4GHz or higher
- Memory: \geq 512MB
- OS: \geq Windows XP

10-2 Minimum System Requirements

- USB2.0 Enhanced Host Controller
- CPU: Intel Pentium4 1.7GHz or higher
- Memory: \geq 256MB
- OS: \geq Windows XP



Caution

■ Please refer the restrictions below when you use ARTCAM.

(1) Recommended System Requirements

If the system specifications do not meet the requirements recommended above, it may be difficult to run at the maximum frame rate.

(2) Connection of Multiple USB Devices

Please be aware that depending on the specifications of the user's PC, it may be difficult to supply the power to the USB devices when multiple USB devices are connected.

(3) USB2.0 cable Extension

We cannot guarantee the functionality of the USB2 camera if the user adopts USB3.0 extension cables or repeaters which are not confirmed by us. With the extension cables or repeaters, the bandwidth of transfer may differ, and thus caused malfunctions such as a low frame rate or recognition failure on the camera.

What may cause the problem is that the regulation of the power lines becomes not enough, and so causes impedance mismatch on data signals.

*For the recommended extension cable, please contact our sales department. (TEL: +81-3-3389-5488)



ARTRAY CO., LTD.

1-17-5 Kouenjikota, Suginami-ku, Tokyo 166-0002 Japan

Tel: +81-3-3389-5488 Fax: +81-3-3389-5486

Email: sales@artray.us URL: www.artray.us